

Excerpt from

The Drafter's World Language

Preview

The following is a sample excerpt from a study unit converted into the Adobe Acrobat format. A sample online exam is available for this excerpt.

The sample text describes the special language shared by drafters all over the world.

If the people of all nations could agree on using one universal language, there would probably be less misunderstanding and much less conflict in our world today. Throughout the ages, however, there have evolved many different languages; the variety reflects the wide range of cultures and communities in our world. Yet, a common world language—one shared by all—actually *is* in use, and it has been in use since the earliest of times. This ancient and universal means of communicating is the *graphic language*. Here, the word “graphic” means “related to the use of lines or marks.” To put it another way, the word “graphic” means “having to do with *pictures*.” Essentially, then, a graphic language is any form of communication relying on pictures. When a drafter creates a drawing, the drafter is using pictures to communicate ideas. Thus, in making drawings, a drafter is effectively using a graphic language—a language of pictures. Because these pictures can be understood by people throughout the world, the graphic language of drafting can be thought of as a “world language.”

The study unit on which this excerpt is based describes how you can use the drafter’s world language to accurately convey your ideas to others. In various drafting occupations, drawings are used to communicate ideas to machinists, carpenters, and other skilled craftworkers who then turn these ideas into real objects. As you study drafting, you’ll learn how to communicate through the skillful use of lines, symbols, and written words. A drawing is intended to provide a complete description of a product. If the drawing is a success, it will show an artisan exactly what he or she is expected to do.

After reading through the following material, feel free to take the [sample exam](#) based on this excerpt.

Contents

DRAFTING AND COMMUNICATING 1

A Good Drafter Is Hard to Find
What Will You Do As a Drafter?

CHARACTERISTICS AND QUALITIES FOR SUCCESSFUL DRAFTING 6

Characteristics of an Ideal Drafting Environment
The Qualities of a Successful Drafter
Getting Started in Drafting

EXAMINATION

The Drafter's World Language

DRAFTING AND COMMUNICATING

In order to draw a complete mechanical structure, electrical device, or building, you must first understand the various methods with which the drafter communicates. Such methods involve drawing lines, lettering, creating projection views, and so on. You'll learn about these methods gradually, one step at a time. Eventually, you'll be able to apply all you've learned to complete a drawing that can be understood by the architects, engineers, design drafters, and technicians you'll associate with in your work. Each step that you take toward this goal—each assignment that you complete—will give you additional confidence, skill, and fulfillment. Soon, you'll be communicating successfully as a drafter.

A Good Drafter Is Hard to Find

In these modern times, there's always a need for good drafters. Drafters are generally *not* trained within a company, so companies must often turn to schools as a main source for the beginning drafters needed to fill any vacancies. After they gain experience, many drafters go on to become engineers. The resulting shortage must be filled, to a large extent, by graduates of all ages from trade and correspondence schools. Age isn't a restriction in drafting work. Many older individuals succeed in entering the workforce as drafters. And, of course, thousands of younger people start their drafting careers each year.

Because of the ever-present need for drafters and the many opportunities that arise in the various drafting occupations, employment directors are constantly looking for drafters. Frequently, the directors searching for new drafters will hire people who want simply to upgrade their skills in the architectural or manufacturing fields. Drafting, which represents the upgrading many people desire, is definitely a white-collar occupation, and it has always been a respected profession.

What Will You Do As a Drafter?

Now, to explore some specific reasons for studying drafting, let's briefly take an overall view of the subject and its place in the fields of engineering and architecture.

The idea behind every work of humanity was first conceived in the mind of some human being. However, implementing an idea sometimes requires extensive calculations and computations. Often, this preparation to build on an idea is quite involved. Inevitably, some type of *hardware* must be produced before the work itself can be constructed. This

hardware, or product, can rarely be produced without *plans*. A drafter completes these plans, or drawings, which show the specific parts to be constructed along with their complete dimensions.

Let's now take a look at some specific applications for drafting as it's commonly used today.

Mechanical Drafting

Mechanical drafters are involved with producing hardware and machinery. In designing machines and other structures, the engineer and drafter must first form a clear *mental image* of the thing to be made. The drafter's job is to then convey this idea to others. Such detailed communication can't be done using geometric shapes alone, but it can be done by combining drawings with specifications and verbal instructions.

Most machines require many separate parts. These parts are assembled, either in a permanent position or—as is the case with *moving* parts—in some particular arrangement. In either case, the parts must fit together exactly. This frequent need for an exact fit means that each part must often be manufactured to match very precise size and shape specifications.

Architectural Drafting

The basic drawings for designing and constructing buildings consist of *floor plans* for each story, side views called *elevations*, and numerous types of views and details of the various parts. Even a relatively simple home will require a considerable number of such drawings.

Architectural detail drawings. Larger structures will require separate sets of framing plans for steel or reinforced concrete. They may also require sets of plumbing plans, heating and ventilation plans, as well as drawings for elevators, electrical wiring, and any special equipment that may be involved in the structures. [Figure 1](#) shows an example of a steel framing plan.

Cost estimate drawings. Before any contracts for construction or manufacturing can be made, cost estimates must be prepared. Such estimates are made from drawings and specifications. The drawings used to estimate costs must show the exact size and shape of all the parts. The kind and quality of materials to be used must also be clearly stated so that costs can be accurately predicted.

Highway and railroad construction plans. Before highways or railroads can be built, *maps* must be made showing the exact location of the route's centerline, the right-of-way lines, and the boundary lines of adjacent property. The drawings must show, in profile, the elevation of the ground and the grade line for the finished highway or railroad. Drafters must also make a number of *sectional views* showing any *cut* or *fill* required along the route. Other details—such as drainage, culverts, bridges, and viaducts—must also be identified and recorded before any contracts for construction can be negotiated.

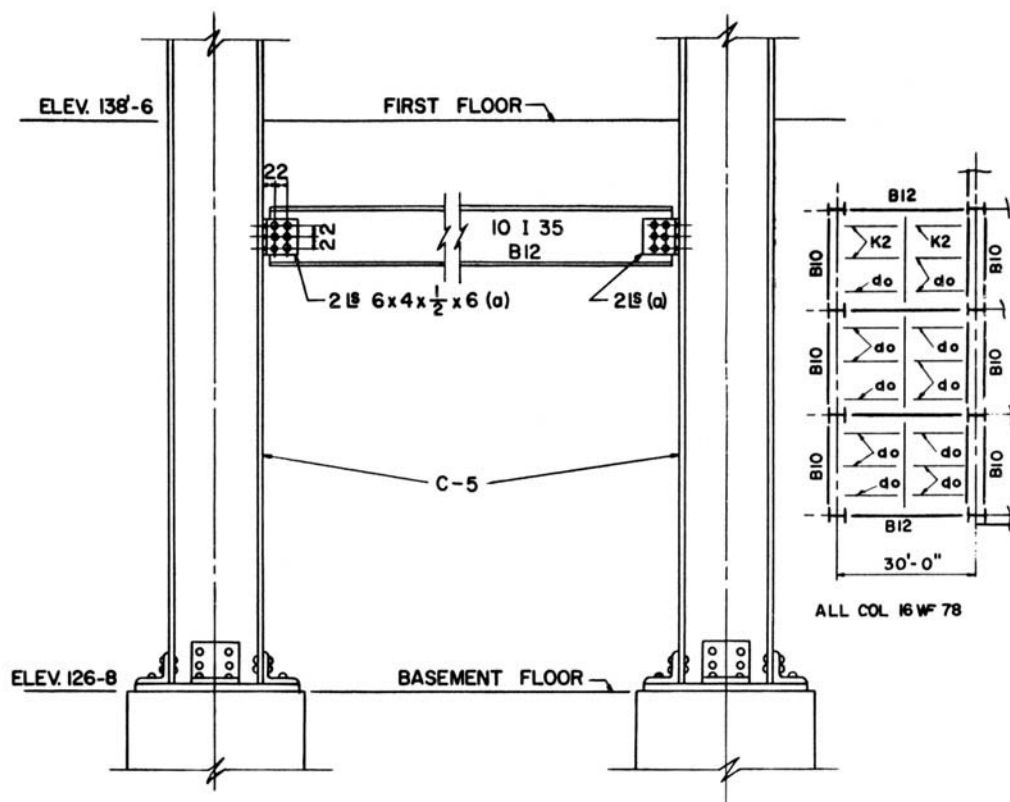

FIGURE 1—This detail drawing illustrates the steel frame construction that would be a part of some larger piece of architecture.

Government Drawings

Government equipment, such as used in the military, must be made to certain specifications and standards demanded by the government. Thousands of drawings conforming to military and government specifications are made annually. Preparing to construct a single battleship or a submarine, for example, will require 40,000 to 50,000 separate drawings.

Electronic Drafting

The production of electronic equipment involves designing and fabricating parts and circuits that must fulfill specific functions. It also involves assembling the various components, wiring, and connections into the complete equipment. The electronic drafter converts engineering ideas and requirements into *working drawings*. These drawings and other information are used as guides for purchasing raw materials, component parts, and hardware and for fabricating, machining, and finishing the detailed parts. Working drawings also assist personnel as they assemble both individual components and entire units. Planning and constructing the radar and radio assembly shown in [Figure 2](#) involved many working drawings created by a number of electronic drafters.

FIGURE 2—The services of many electronic drafters were required to complete the component drawings used when constructing this array of communication equipment.



Tool Design

Manufacturing any product in large quantities will typically require some sort of special *tool* to make the mass production possible. Often, the engineered parts must be made exactly alike because they'll be interchanged when in service. Therefore, such parts must all be produced with the same tools. Eli Whitney created the first *tooling* when he made interchangeable gun parts for the American army during the War of 1812. Drill jigs and mill fixtures, types of tooling, are used for clamping and precisely positioning material while the machining operations are being performed. The machining operations will thus result in the production of identical parts.

Tool designers conceive of the tools, plan out how they would look, and draft the working drawings used to manufacture the tools. *Tool and die makers* actually build the tools. Tool designers play an important part in most manufacturing plans. The aircraft pictured in [Figure 3](#) is an example of a product that would require the use of special tooling in its production.

FIGURE 3—The McDonnell-Douglas Corporation employed dozens of tool designers to develop the special tooling required for producing and maintaining this Harrier jet.



Aerospace Drafting

Many complex mathematical calculations are necessary to place a satellite in orbit. Many sciences are also involved. But nothing actually happens until the hardware is designed and produced. Building a helicopter, plane, satellite, or spacecraft requires separate drawings for thousands of parts. In order to function properly, some of these parts must be precision-made with exceptional accuracy. For example, consider the space shuttle shown in [Figure 4](#). All the parts of this craft must function reliably to ensure a successful mission into space. Each system and each component had to be drawn in great detail before this shuttle was built.

FIGURE 4—Planning and building this space shuttle required the creation of thousands of separate drawings.



Sales Presentation—Proposal Drafting

Many times, a company will submit a *proposal* as part of its sales promotion. This proposal is frequently a printed booklet describing in detail what the company proposes to furnish or supply. A proposal is illustrated with many kinds of drawings, including *pictorial drawings*, which are drawings that show how something would look as though viewed in a photograph. In [Figure 5](#) is an example of a pictorial drawing that would be part of a product's description.

In addition to the specific applications just described, many other drafting occupations exist. Therefore, you can begin to see why good drafters have always been in high demand. When you're just starting in the workplace, you'll find drafting to be an excellent tool for testing and developing your imagination. In design work, imagination plays a definite role. For example, many problems in engineering design can have more than one correct solution. As part of his or her job, a designer may sometimes need to conceive of and graphically describe several of these possible solutions. A background in drafting will make such a task second nature.

FIGURE 5—A drafter trained in technical illustration created this sales presentation drawing.



CHARACTERISTICS AND QUALITIES FOR SUCCESSFUL DRAFTING

In order to perform at top efficiency as a drafter, you must make sure that your drafting room and your approach to your work are suitable. The quality of your drawings can be strongly influenced by the conditions in which you work and your mood in the workplace.

Characteristics of an Ideal Drafting Environment

Adequate lighting. Always make certain that you have good light. Be sure your drafting board is illuminated so you can see small details comfortably. If you prefer doing your drawings in natural sunlight, avoid glare. Even the best lighting is useless if you locate your work in shadows. Therefore, be sure to adjust your position so that you're not drawing in the shadow of your triangle, compass, or shoulder.

Cleanliness. You'll be amazed at how easily particles of dirt, drops of coffee, and a variety of smudges can become a part of your drawing. Before you start drawing, be sure that your drafting board and tools have been wiped clean. Be sure your hands are clean. Pencil shavings and wastepaper should be discarded in proper containers, away from your drawing. Untidy habits will reveal themselves in your work. Keep your tools clean and neatly arranged, as illustrated in [Figure 6](#). Give yourself the best chance to produce drawings that have a polished look—the look of efficiency.

FIGURE 6—Orderliness promotes efficiency.

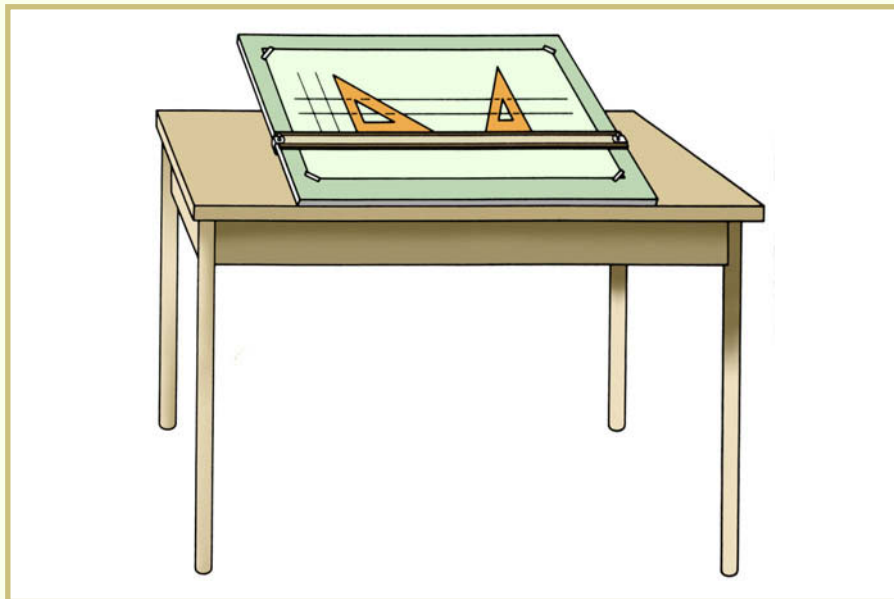

Noise control. In an engineering or architect's office, noise can be a very distracting influence. The drafting area, though, should be a quiet zone. Disconcerting sounds from loud conversation or radio and television programs can be annoying to anyone trying to concentrate. Sometimes, however, quiet, slow music has a calming influence. Tailor your environment to fit your tastes and to suit the work that's at hand.

The Qualities of a Successful Drafter

The proper frame of mind. You've got to feel good to produce good drawings. Adopt the right frame of mind so that you can think clearly about your drawings. Because you're paid for using your mind as well as your hands, you'll need to develop an ability to concentrate on your drawings. Here, a good mental outlook will be an important factor in the measure of your success.

Respect for others. In your studies, you'll often prepare assignments by yourself. In an engineering or architect's office, however, you'll be constantly dealing with others. Treat them the way you would like them to treat you; try to promote an atmosphere of respect and harmony. After all, working as a drafter is similar to working as a member of a production team. Determine how you can best fit into your "team." Look for ways to make important contributions so that you'll come to have a vital role in each project. By following this tactic, you'll soon gain respect and cooperation from all your associates.

A proper work ethic. Frequently, individuals lose their jobs or are held back in their professions more often because of poor attitude than because of any other single shortcoming. Remember that company rules, policies, and managerial decisions—including those made by your immediate supervisor—are usually the result of planning. The directives that may seem senseless at first are often well-reasoned attempts at improving the business. Try to carry out the objectives of your company. Don't be contrary without good reason.

Part of portraying a correct work ethic has to do with good attendance—being on the job promptly at starting time—and with working conscientiously. Adopting a proper work ethic will help you gain advancements, and you'll also gain the admiration of your supervisors and fellow employees.

Getting Started in Drafting

As eager as you are to rush into the world of drafting—to create the larger, more complex drawings—you'll still have to start at the beginning. A good drafter is one who can apply the basic skills with excellence; one who knows the *fundamentals* very well.

Abilities with these basic skills are often lacking in the workplace. This fact was clearly demonstrated in a survey directed to nearly 400 firms employing approximately 50,000 people in drafting and drafting-related occupations. This survey revealed that the large majority of these employees were inadequately trained in the use of drawing instruments, pencil techniques, and erasing techniques. Far more than half of the new drafters employed didn't understand the basic concepts well enough to communicate design ideas. Lettering and linework, general drafting techniques, and dimensioning and tolerancing were mentioned in the survey as subjects not covered well enough in the training of new drafting personnel.

Beginning now, at the start of your studies on drafting, you must strive to *learn the basics*. Now is the time to begin developing the skills that will enable you to consistently create very professional drawings and so achieve a reputation of excellence in your field.